



**Rockland County Sewer District
Western Ramapo Advanced
Wastewater Treatment Plant Project**

HARMONIC STUDY

Prepared By
Pierre Archambault, PEng
Power Survey International Inc.
8025 Trans Canada Hwy.
St-Laurent, QC
H4S 1S4
CANADA

10 October 2006

TABLE OF CONTENTS

1.	GENERAL
1.1	Purpose of this Study
1.2	Data
1.3	Assumptions
1.4	Simulation One Line Diagram
1.5	Load Flow One Line Diagram
2.	RESULTS
2.1	Scenario 1: no Filters
2.3	Scenario 2: 1x600 KVAR, 4.3rd harmonic filter
3.	CONCLUSIONS
3.1	Comparing Scenarios
3.2	Recommendations

1. GENERAL

1.1 Purpose of this Study

The purpose of this study is to confirm the need of a harmonic filter and to size it for obtaining harmonic mitigation at the Point of Common Coupling as to comply with IEEE 519 guidelines. This study is based on the ETAP Power Station simulation software version 5.0.2.

IEEE 519 Guidelines for Current Distortion:

IEEE Std 519-1992

IEEE RECOMMENDED PRACTICES AND REQUIREMENTS

Table 10-3—Current Distortion Limits for General Distribution Systems (120 V Through 69 000 V)

Maximum Harmonic Current Distortion in Percent of I_L						
Individual Harmonic Order (Odd Harmonics)						
I_{sc}/I_L	<11	11≤h<17	17≤h<23	23≤h<35	35≤h	TDD
<20*	4.0	2.0	1.5	0.6	0.3	5.0
20<50	7.0	3.5	2.5	1.0	0.5	8.0
50<100	10.0	4.5	4.0	1.5	0.7	12.0
100<1000	12.0	5.5	5.0	2.0	1.0	15.0
>1000	15.0	7.0	6.0	2.5	1.4	20.0

Even harmonics are limited to 25% of the odd harmonic limits above.

Current distortions that result in a dc offset, e.g., half-wave converters, are not allowed.

* All power generation equipment is limited to these values of current distortion, regardless of actual I_{sc}/I_L .

where
 I_{sc} = maximum short-circuit current at PCC.
 I_L = maximum demand load current (fundamental frequency component) at PCC.

Assuming I_{sc}/I_L 20<50 the limits are:

7% for <10th harmonics

3.5% for 11th to 16th harmonics

2.5% for 17th to 22nd harmonics

1.0% for 23rd to 34th harmonics

0.5% for 35th and higher harmonics

8.0% for THD-I values

IEEE 519 Guidelines for Voltage Distortion:

Table 10-2—Low-Voltage System Classification and Distortion Limits

	Special Applications [*]	General System	Dedicated System [†]
Notch Depth	10%	20%	50%
THD (Voltage)	3%	5%	10%
Notch Area (A_N) [‡]	16 400	22 800	36 500

NOTE — The value A_N for other than 480 V systems should be multiplied by $V/480$

*Special applications include hospitals and airports.

†A dedicated system is exclusively dedicated to the converter load.

‡In volt-microseconds at rated voltage and current.

1.2 Data

The following documents were available and used for programming the ETAP simulation model:

Overall Floor Plan @ 1/16" from 8/10/06, drawing No A-3
Electrical Single Line Diagram 480 V Switchgear, drawing No E-6
Single Line Diagram with power cable notes, drawing No E-6A
Single Line Diagram MCC BR1A, drawing No E-7
Single Line Diagram MCC BR1B, drawing No E-7A
Single Line Diagram HWS1A/HWS1B, drawing No E-8
Single Line Diagram EF1A/EF1B, drawing No E-9
Single Line Diagram MCC SB1A/SB1B, drawing No E-10
Rockland County Western Ramapo Advanced Wastewater Treatment Plant Project,
Job No 30447-48248, Excel Spreadsheet from 9/20/2006, sheets 1 to 15, 19 to 21

1.3 Assumptions

Following the data specified above and having installed the one line diagram on ETAP, a load flow run was performed assuming a 75% service factor for all loads. A main distribution 2500 KVA (4.16 kV / 480 V) transformer was programmed, as well as the utility set at 100 MVA at 4.16kV. The harmonic current injection on all drives was chosen typical Rockwell 6-pulse VFD.

Drive Harmonic Current Spectrum typical Rockwell 6-pulse:

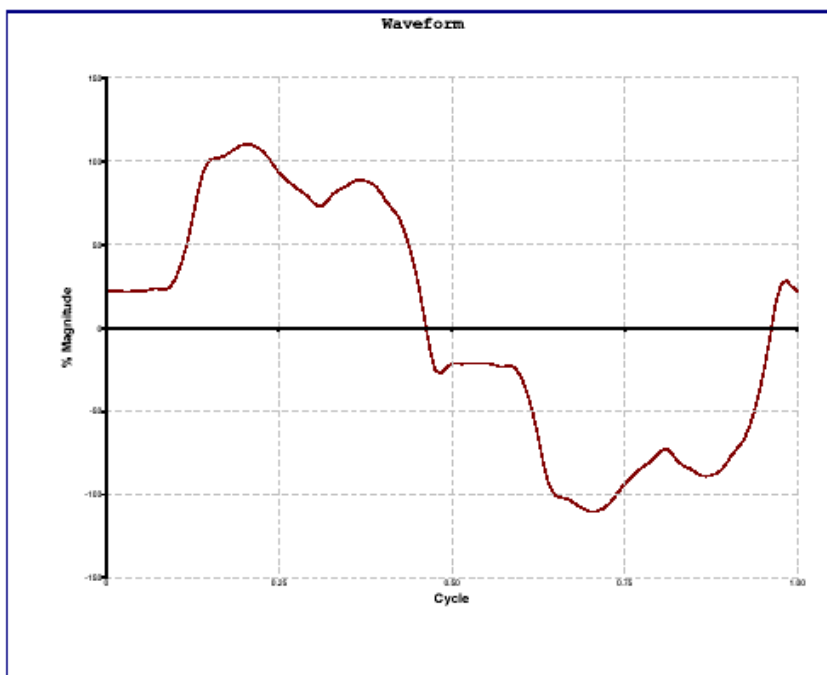

Harmonic	%
1	100
2	0.16
3	0.59
4	0.12
5	23.52
6	0.1
7	6.08
8	0.03
9	0.09
10	0
11	4.57
12	0.03
13	4.2
14	0.03
15	0.06
17	1.8
19	1.37
23	0.75
25	0.56
29	0.49
31	0.54

The main tie breaker (breaker No 4) in the main switchboard was assumed closed and all MCC tie breakers open. This configuration offers best voltage balance all over.

1.4 Simulation One Line Diagram

One-Line Diagram - OLV1

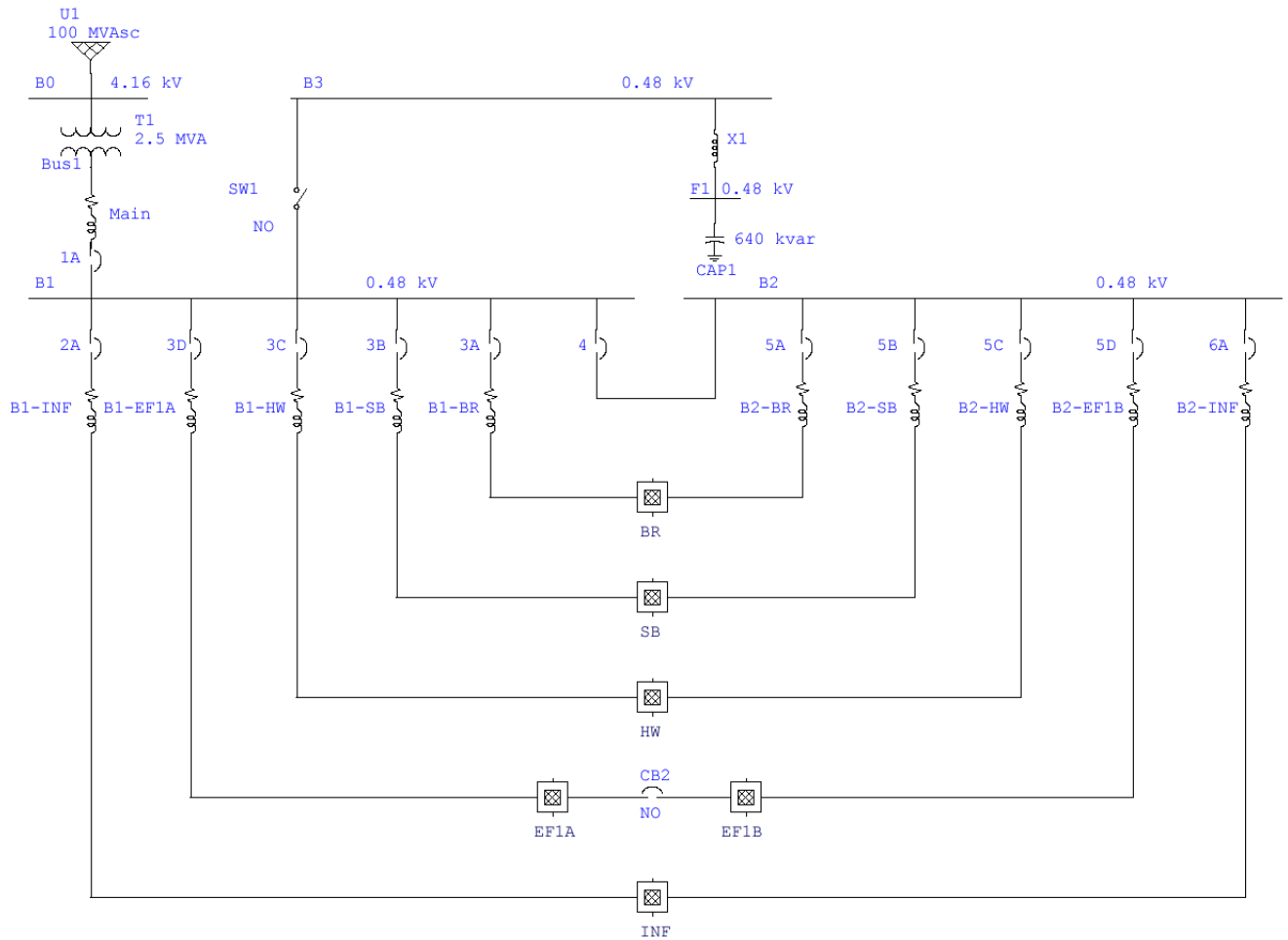

HARMONIC STUDY
 Rockland County Sewer District
 Wastewater Treatment Plant Project

MCC BR1A and BR1B

One-Line Diagram - OLV1=>BR

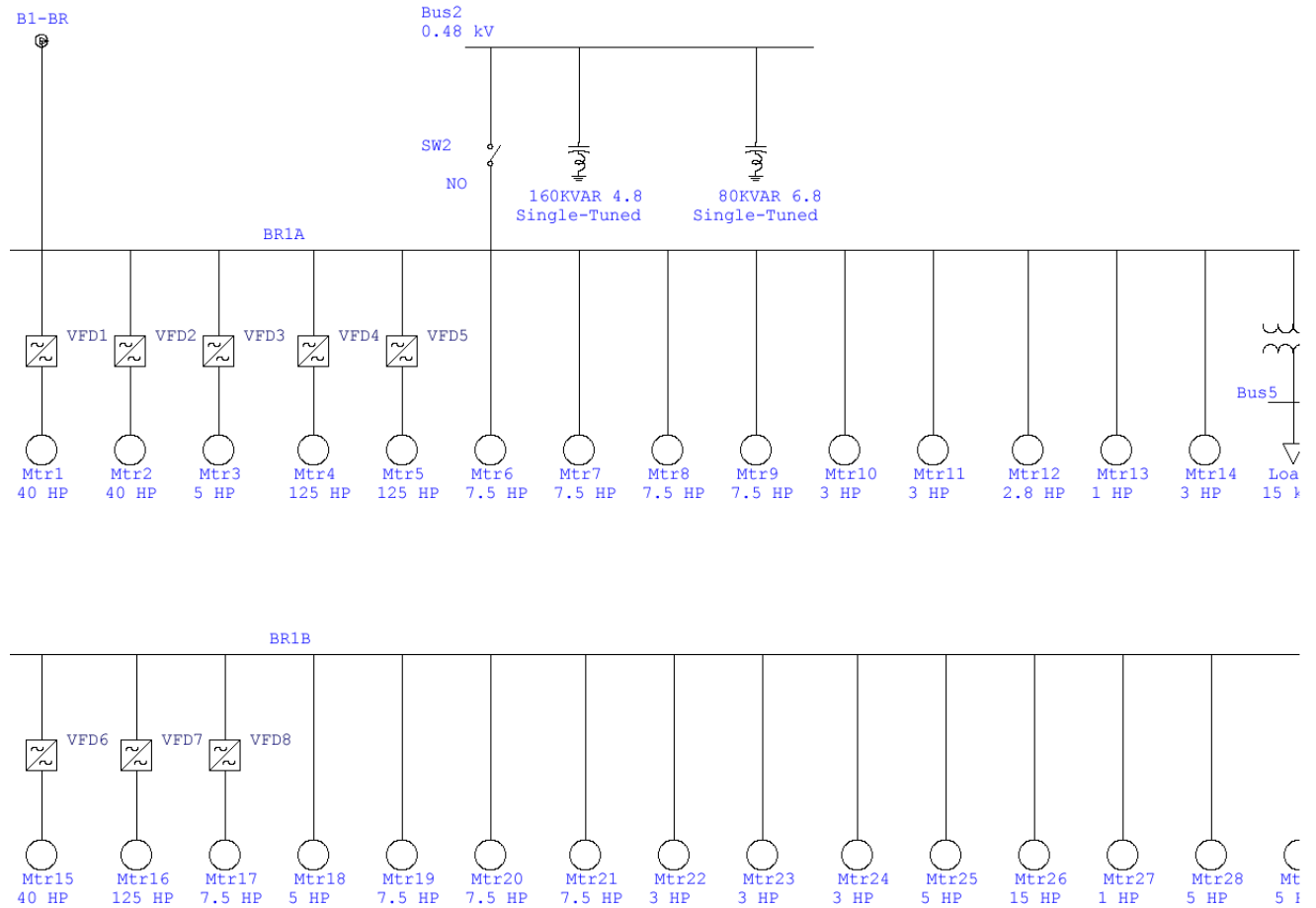

HARMONIC STUDY
Rockland County Sewer District
Wastewater Treatment Plant Project

(Continuation)

One-Line Diagram - OLV1=>BR

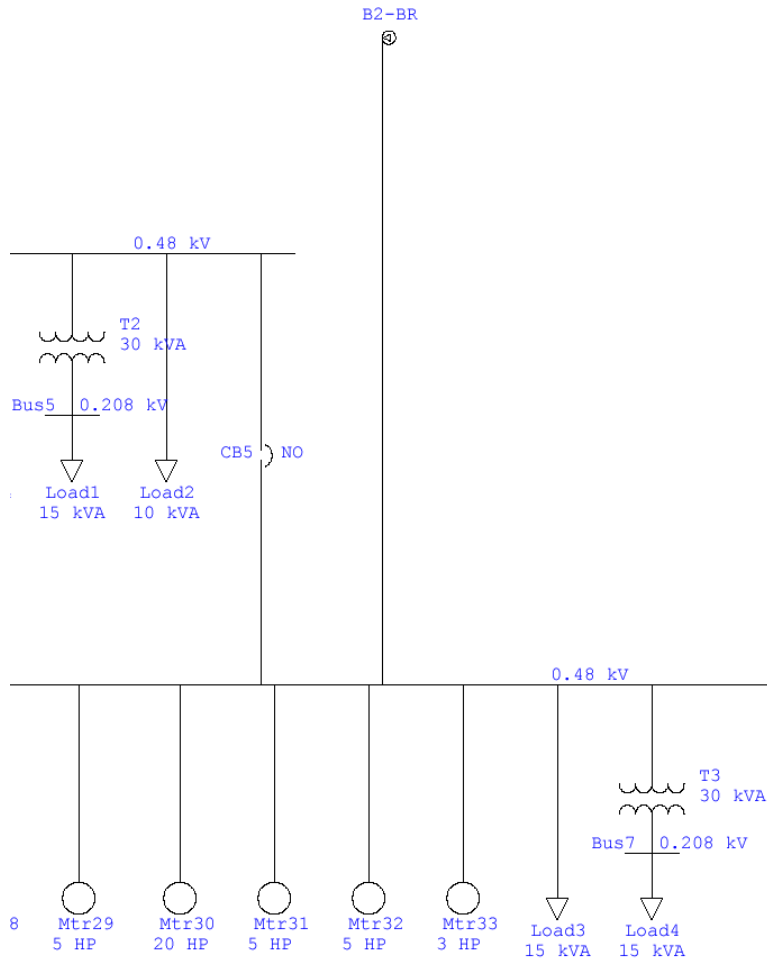

HARMONIC STUDY
 Rockland County Sewer District
 Wastewater Treatment Plant Project

MCC SB1A and SB1B

One-Line Diagram - OLV1=>SB

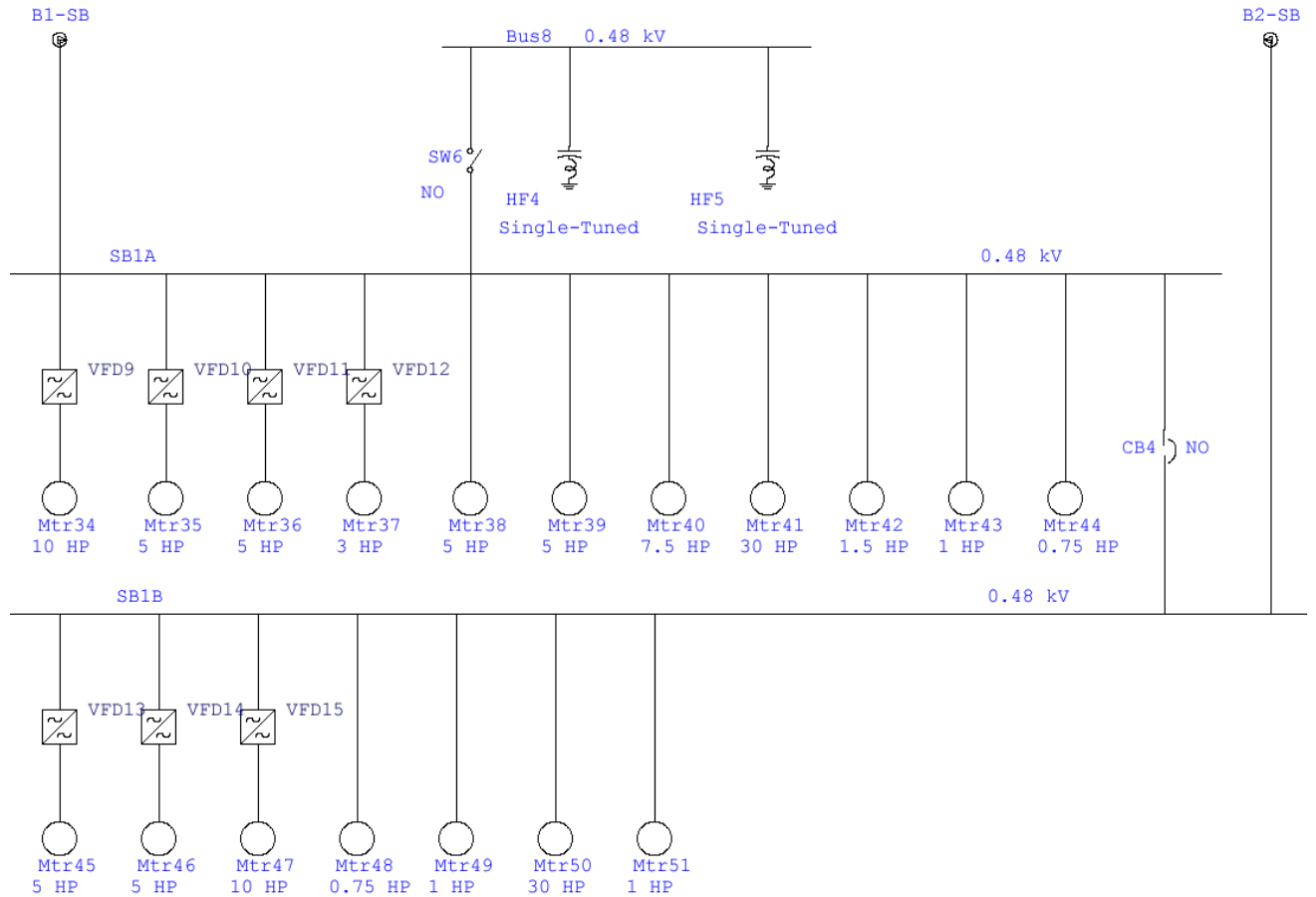

HARMONIC STUDY
Rockland County Sewer District
Wastewater Treatment Plant Project

Switchgear HW1A / HW1B and MCC HW1A / HW1B

One-Line Diagram - OLV1=>HW

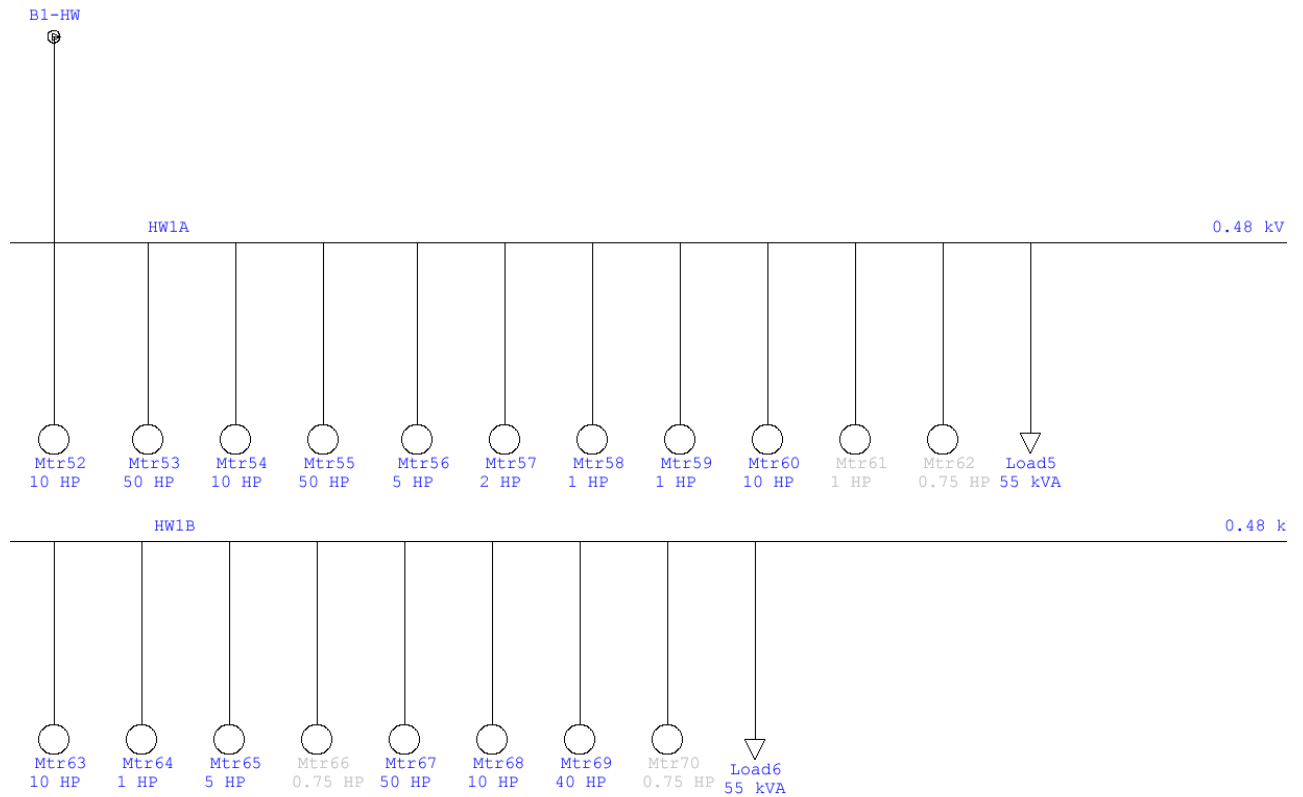

HARMONIC STUDY
Rockland County Sewer District
Wastewater Treatment Plant Project

(Continuation)

One-Line Diagram - OLV1=>HW

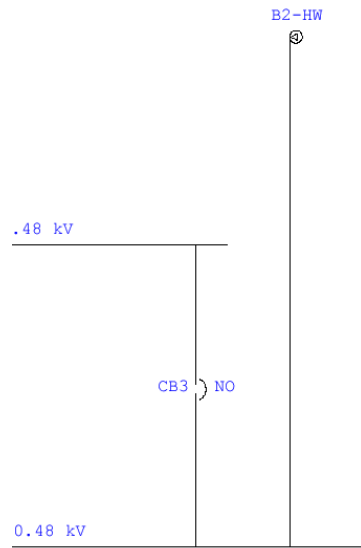

HARMONIC STUDY
 Rockland County Sewer District
 Wastewater Treatment Plant Project

Switchgear EF1A and MCC EF1A

One-Line Diagram - OLV1=>EF1A

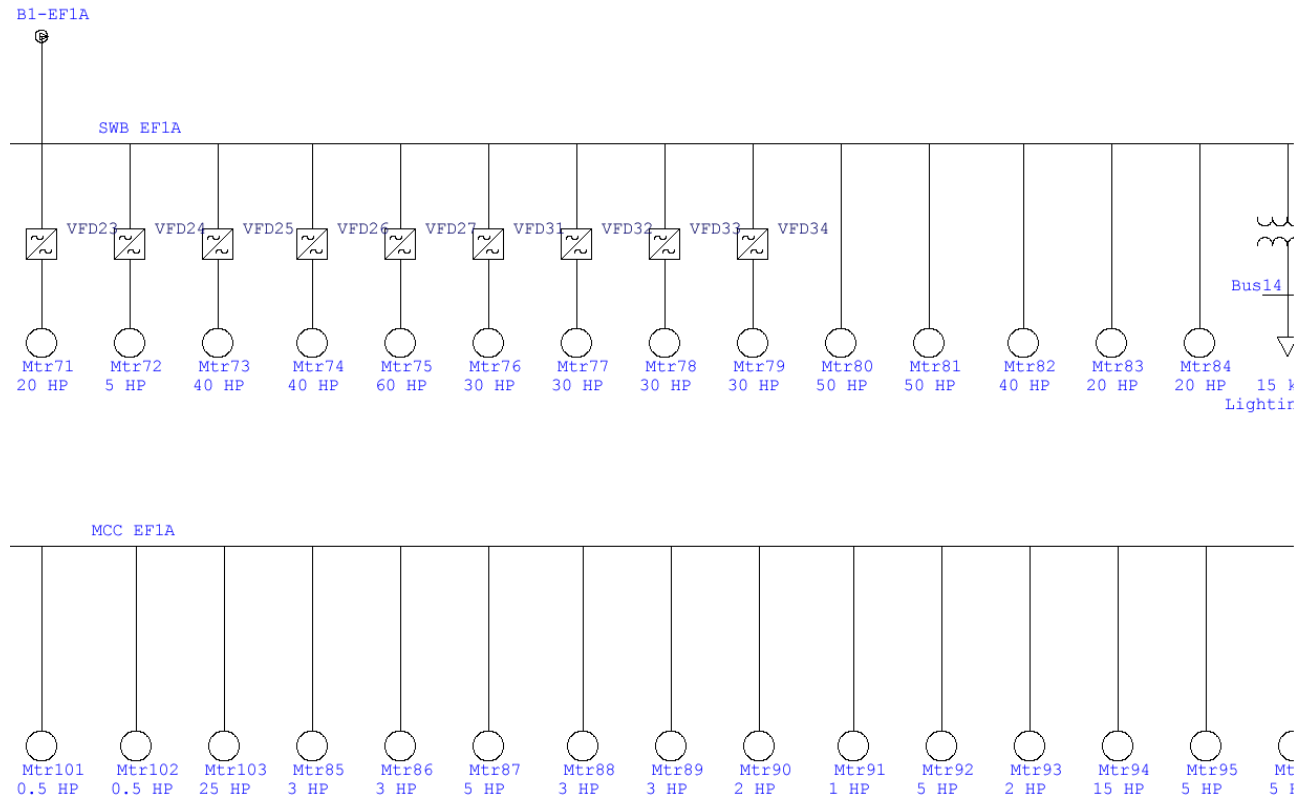

HARMONIC STUDY
Rockland County Sewer District
Wastewater Treatment Plant Project

(Continuation)

One-Line Diagram - OLV1=>EF1A

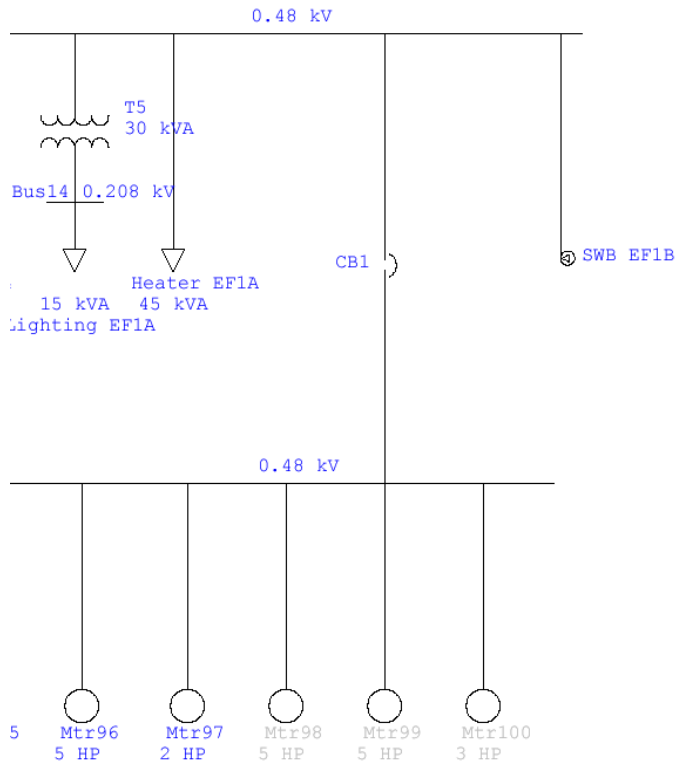

HARMONIC STUDY
 Rockland County Sewer District
 Wastewater Treatment Plant Project

Switchgear EF1B and MCC EF1B

One-Line Diagram - OLV1=>EF1B

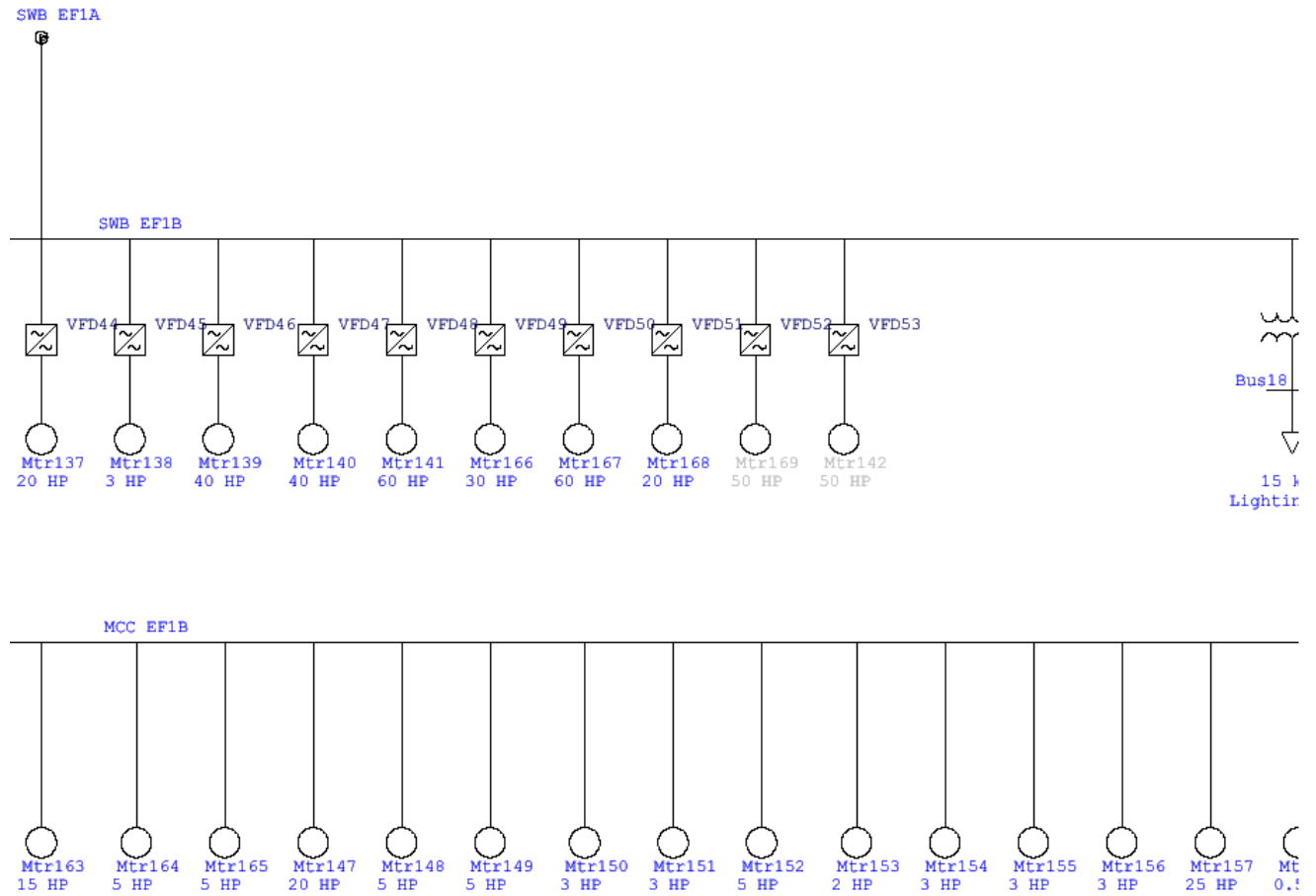

HARMONIC STUDY
Rockland County Sewer District
Wastewater Treatment Plant Project

(Continuation)

One-Line Diagram - OLV1=>EF1B

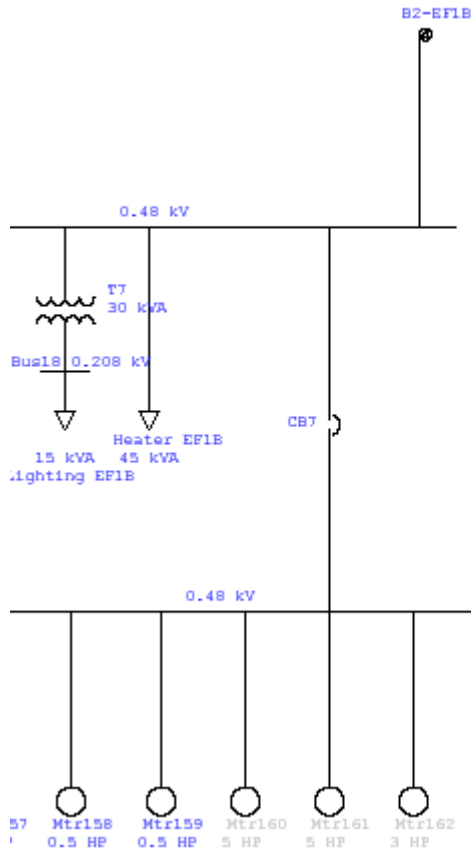

HARMONIC STUDY
Rockland County Sewer District
Wastewater Treatment Plant Project

MCC INF1A and INF1B

One-Line Diagram - OLV1=>INF

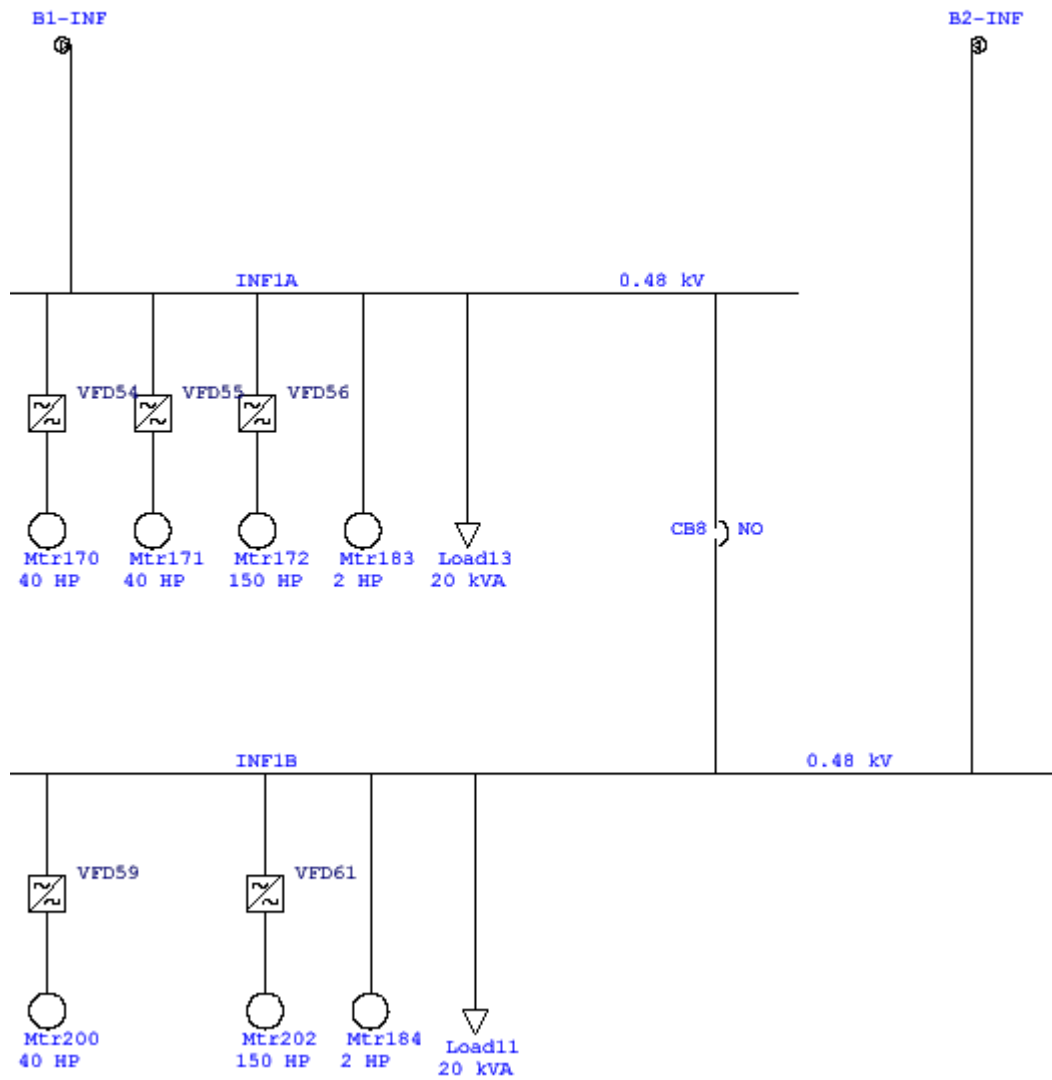

1.5 Load Flow One Line Diagram with 600 KVAR Filter

One-Line Diagram - OLV1

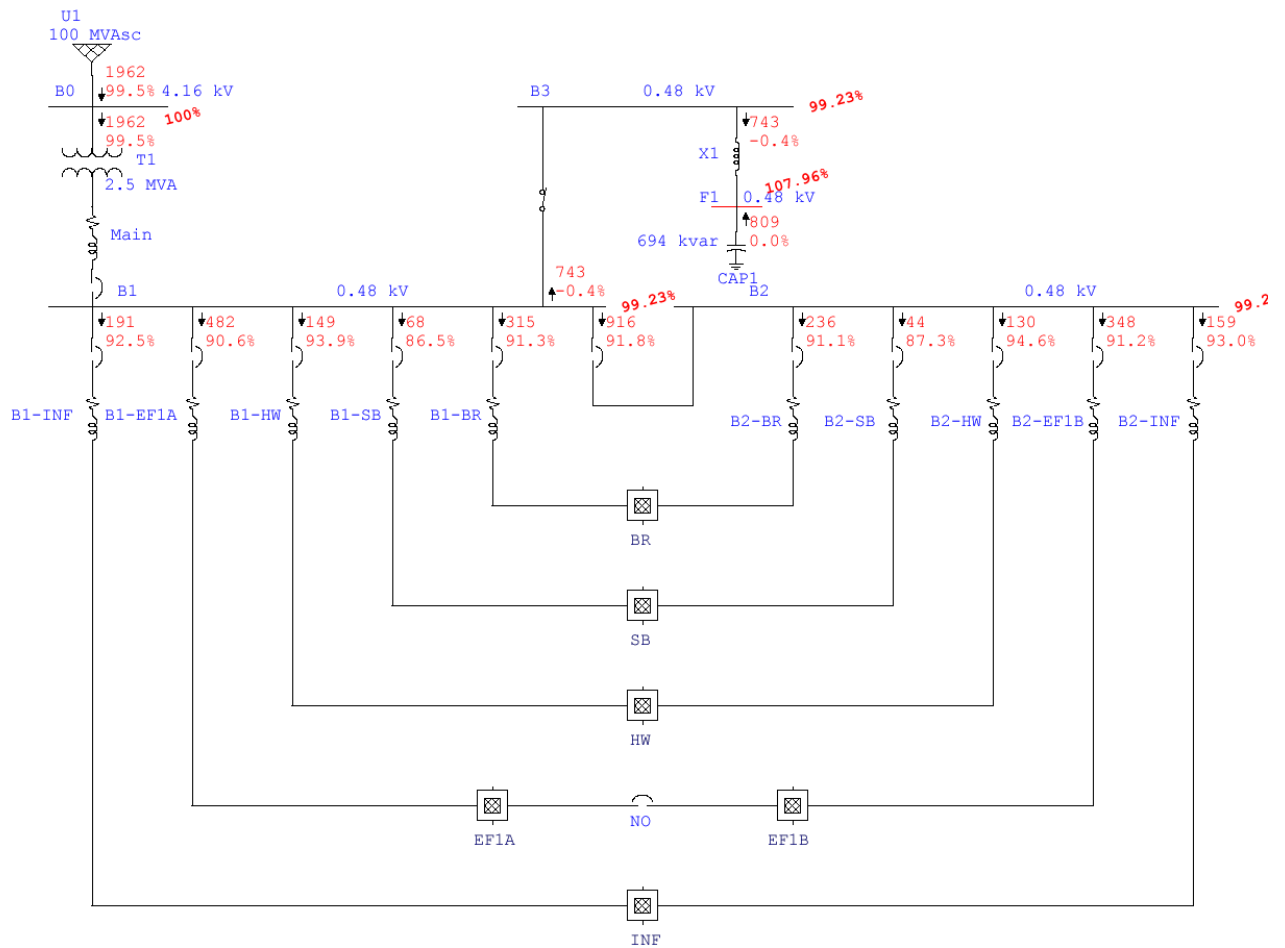

2. RESULTS

2.1 Scenario 1: No Filters

The load flow obtained by the simulation show a total load of 2165 KVA (PF = 89.7%) of the main transformer. The harmonic current spectrum on the main transformer secondary side indicates higher than permissible 5th harmonic current (10.95% > 7%) and higher than permissible THD-I (11.64% > 8%). The voltage THD-V at the main transformer secondary side (bus B1 and bus B2) is 4.96%, borderline to the IEEE 519 limit of 5%.

CURRENT SPECTRUM - MAIN TRANSFORMER SECONDARY SIDE:

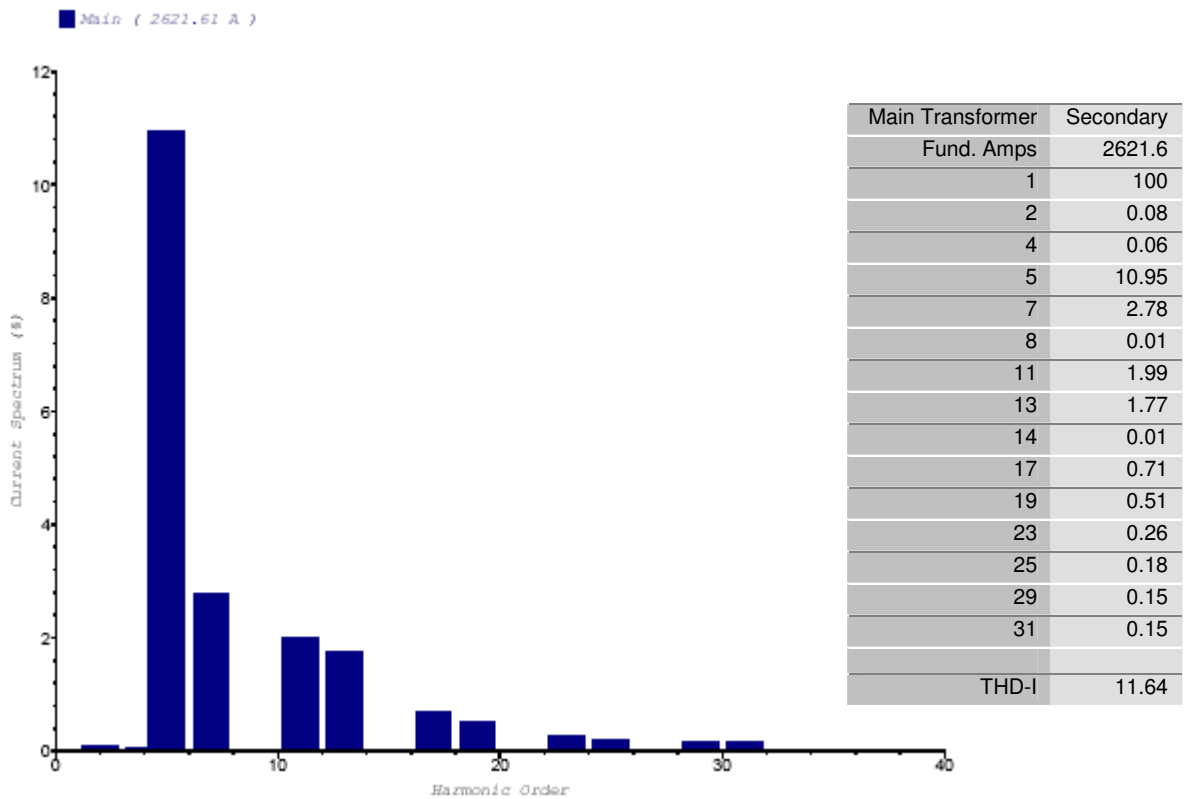

HARMONIC STUDY
 Rockland County Sewer District
 Wastewater Treatment Plant Project

VOLTAGE SPECTRUM - MAIN TRANSFORMER SECONDARY SIDE:

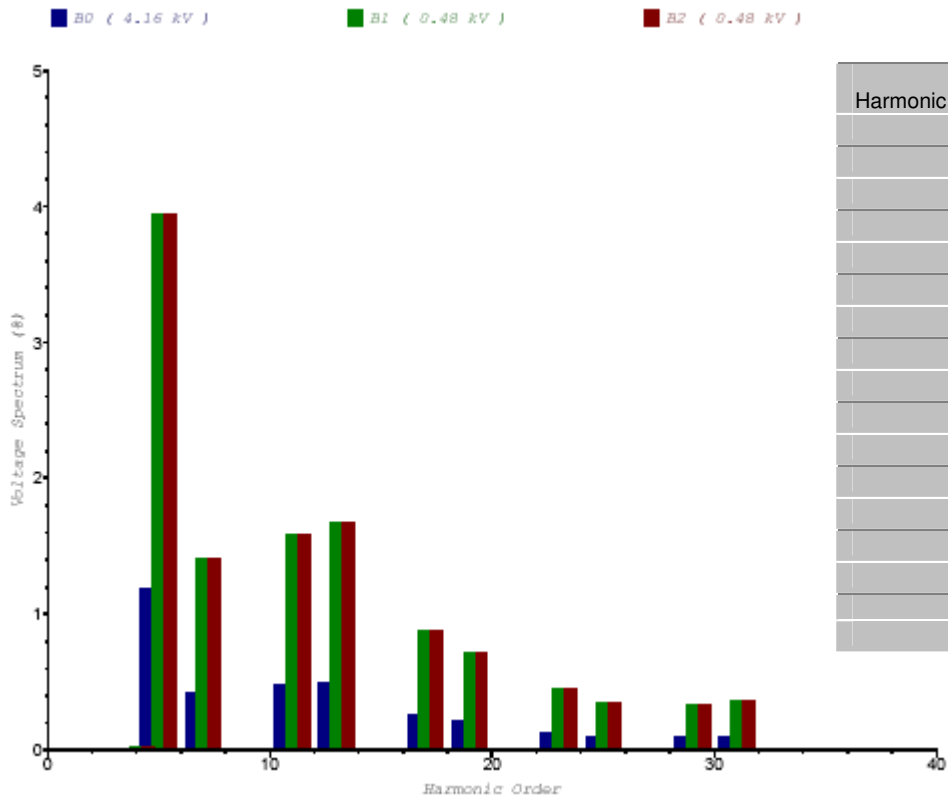

Bus Harmonic Number	B0	B1 & B2
1	100	100
2	0.00	0.01
4	0.01	0.02
5	1.19	3.94
7	0.42	1.40
8	0.00	0.01
11	0.48	1.59
13	0.50	1.67
14	0.00	0.01
17	0.26	0.88
19	0.21	0.72
23	0.13	0.44
25	0.10	0.34
29	0.09	0.33
31	0.10	0.36
THD-V	1.50	4.96

2.2 Scenario 2: 600 KVAR 4.3rd harmonic filter

One 4.3 rd harmonic filter was connected. The harmonic current spectrum on the main transformer secondary side indicates acceptable 5th harmonic current of 6.21% and an acceptable THD-I factor of 6.94%. The voltage THD factor at the transformer secondary is 2.98%, falling well below IEEE 519 limit of 5%.

CURRENT SPECTRUM - MAIN TRANSFORMER SECONDARY SIDE:

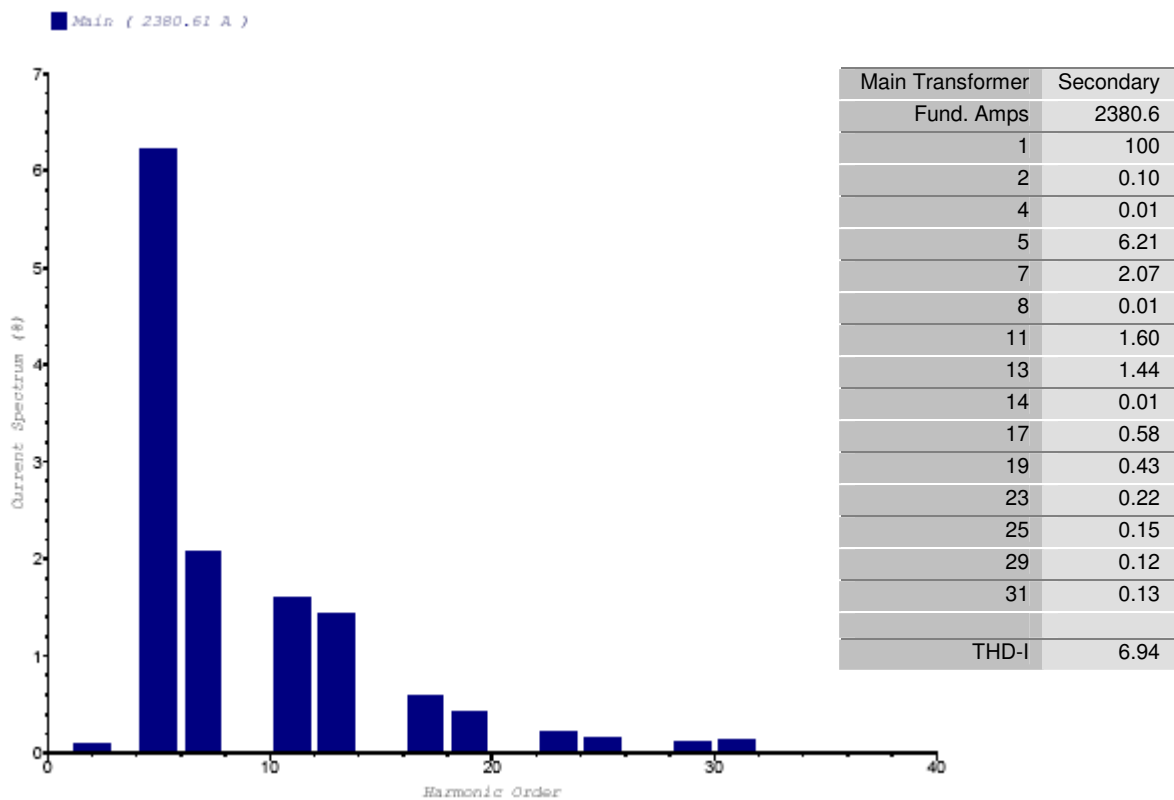

HARMONIC STUDY
 Rockland County Sewer District
 Wastewater Treatment Plant Project

VOLTAGE SPECTRUM - MAIN TRANSFORMER SECONDARY SIDE:

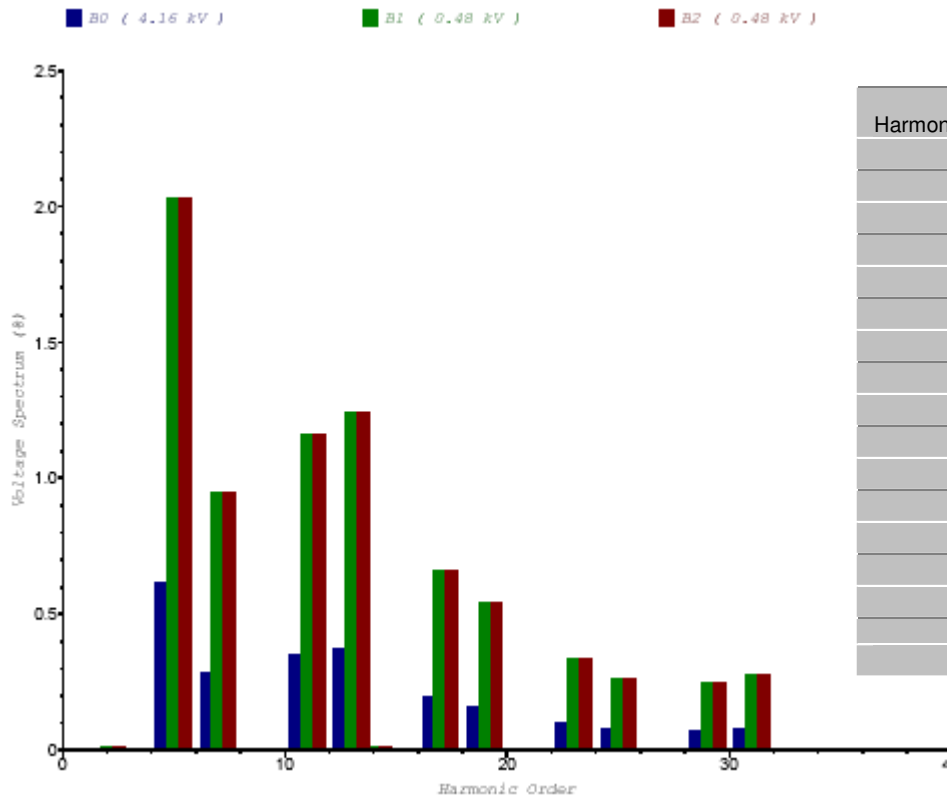

3. CONCLUSIONS

3.1 Comparing Scenarios

The following table highlights the results for current and voltage harmonics (in % values, unless otherwise stated) for the secondary side of the main 2500 KVA transformer:

Transformer n	No Filter Currents		600 KVAR @ 4.3 Currents		Bus n	No Filter Voltages		600 KVAR @ 4.3 Voltages	
	Primary	Secondary	Primary	Secondary		B0	B1&B2	B0	B1&B2
1	345.0 A	2621.6 A	273.4 A	2380.6 A	1	100	100	100	100
2	0.08	0.08	0.10	0.10	2	0.00	0.01	0.00	0.01
4	0.06	0.06	0.01	0.01	4	0.01	0.02	0.00	0.00
5	11.02	10.95	6.23	6.21	5	1.19	3.94	0.61	2.03
7	2.80	2.78	2.07	2.07	7	0.42	1.40	0.29	0.95
8	0.01	0.01	0.01	0.01	8	0.00	0.01	0.00	0.01
11	2.00	1.99	1.60	1.60	11	0.48	1.59	0.35	1.16
13	1.78	1.77	1.45	1.44	13	0.50	1.67	0.37	1.24
14	0.01	0.01	0.01	0.01	14	0.00	0.01	0.00	0.01
17	0.71	0.71	0.59	0.58	17	0.26	0.88	0.20	0.66
19	0.52	0.51	0.43	0.43	19	0.21	0.72	0.16	0.55
23	0.26	0.26	0.22	0.22	23	0.13	0.44	0.10	0.34
25	0.18	0.18	0.15	0.15	25	0.10	0.34	0.08	0.26
29	0.15	0.15	0.12	0.12	29	0.09	0.33	0.07	0.25
31	0.15	0.15	0.13	0.13	31	0.10	0.36	0.08	0.00
THD-I	11.73	11.64	6.96	6.94	THD-V	1.50	4.96	0.90	2.98

Numbers in red do not comply with the IEEE 519 guidelines. With a 600 KVAR 4.3 harmonic filter, the calculated power factor at the transformer primary side is already 99.3%, but all harmonic distortions are within acceptable limits.

3.2 Recommendation

No further increase of filter KVAR beyond 600 KVAR recommended due to the small reactive power headroom on this system. The detuned capacitor bank shall be tuned to the 4.3 rd harmonic or higher.