

Talladega Project

ETAP SIMULATION

Prepared by:

Carlos Reinel
Senior Engineer
R&D Department
Power Survey International

Approved by:

Pierre Archambault, PEng.
VP Engineering
Power Survey International Inc.

8 December 2009

TABLE OF CONTENTS

1.	GENERAL
1.1	Purpose of this Study
1.2	Data Available
2.	RESULTS
2.1	ETAP Single Line Diagram
2.2	Voltage and Current Harmonics at the LV side

1. GENERAL

1.1 Purpose of this Simulation

The purpose of this study is to verify the measurements done on the 23rd of October 2009 against a system simulation using ETAP Software Version 5.5.6

1.2 General Data Available

Following files and documents were available:

Talladega Castings Single-line1.pdf

tc_noload_A_V_THD.xls

tc_noload_lb.xls

tc_noload_power.xls

tc_noload_Vb.xls

1.3 Utility Data

Isc = 220.966 MVA sc @ 46 kV

X = 40.432 % (100 MVA)

R = 20.331 % (100 MVA)

X = 8.56 Ohms

R = 4.30 Ohms

Harmonic Voltages:

Adjusted for reproducing the voltage distortions measured at the LV bus for no-load and no-filter condition. The no-load and no-filter % harmonic voltages are averaged from *tc_noload.xls*, lines 353 to 480 and lines 1124 to 1209:

Table 1: LV Bus Averaged Harmonic Voltages

Harmonic No	Average % Vh
5	1.888
7	0.699
11	0.209
13	0.265

Adjusted harmonic voltage injection at the PCC:

Table 2: PCC Harmonic Voltages

Harmonic No	% Vh
5	1.71
7	0.57
11	0.12
13	0.17

1.4 Filter Data in ETAP

X1	0.03124 Ohms (82.87 μ H)	300 KVAR nominal
X2	0.05208 Ohms (138.15 μ H)	200 KVAR nominal
X3	0.01945 Ohms (51.59 μ H)	300 KVAR nominal
X4	0.01028 Ohms (27.27 μ H)	200 KVAR nominal

2. RESULTS

2.1 ETAP Single Line Diagram

PCC Voltage Harmonics: as per Table 2

LV Voltage: adjusted up to 104.74% of 480V (averaged during no-load and no-cap operation)

Cap 1 (600 KVAR) = ON

Cap 2 (1800 KVAR) = OFF

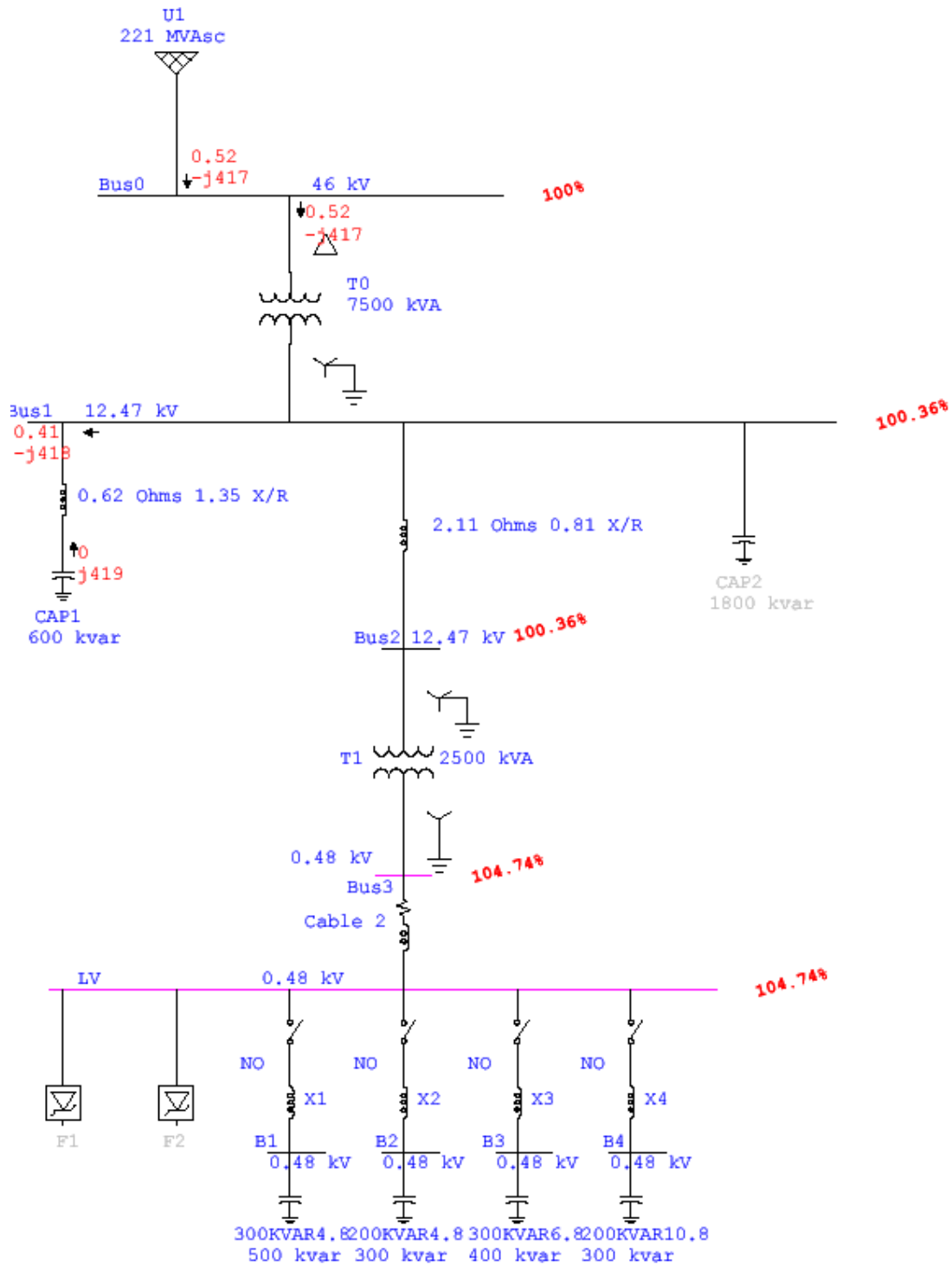

ETAP Simulation – Talladega Project

2.2 LV Harmonic Voltages and Currents

The Excel Spreadsheet *tc_noload.xls* is taken here as main reference. This spreadsheet condenses all the measured values more conveniently in a single file. All harmonic voltage and current percent values presented next are derived from sheets *tc_noload_Vb_pct* and *tc_noload_lb_pct*. The summary tables listed below are from sheets *Vb* and *lb*.

Harmonic Voltage % Values

Line	KVAR		% 5th		% 7th		% 11th		%13th	
	Measured	ETAP	Measured	ETAP	Measured	ETAP	Measured	ETAP	Measured	ETAP
353-...	0	0	1.8880	1.8860	0.6999	0.7006	0.2091	0.2012	0.2645	0.2615
482	399	378	0.7136	0.3752	0.4757	0.4128	0.2039	0.1335	0.1699	0.1789
720	650	617	0.5722	0.2534	0.3702	0.3299	0.2020	0.1101	0.1346	0.1484
872	989	941	0.6993	0.2743	0.1665	0.0742	0.1998	0.0673	0.1332	0.0946
1015	1256	1191	0.7573	0.2845	0.2305	0.0792	0.0659	0.0120	0.0329	0.0357

Harmonic Current % Values

Line	KVAR		% 5th		% 7th		% 11th		%13th	
	Measured	Measured	ETAP	Measured	ETAP	Measured	ETAP	Measured	ETAP	
482	399	18.0220	17.2437	2.4176	2.29491	0.4396	0.308851	0.2198	0.327925	
720	650	13.2153	11.5253	1.9074	1.81601	0.4087	0.252213	0.2725	0.269323	
872	989	9.0416	7.55948	2.0796	1.98403	0.6329	0.236449	0.4521	0.249326	
1015	1256	7.3487	5.99277	1.8732	1.57312	0.7925	0.255446	0.4323	0.252111	

The harmonic currents resulting from the ETAP simulation are generally very close to the measured values. The simulation shows also sensitivity to parameter changes, specially filter tuning frequency and circuit impedances. The results are though basically in line with the measured values and show clearly the effect of PCC voltage distortion on the filter currents. Some major deviations for the 11th harmonic current are though apparent: the model predicts lower 11th harmonic currents, which could be explained by some additional resonance not considered in this model.